

DELTA TP AC-evo

Skids, Ramps and Double-Pallet Handling

Capacity (kg): 1200 - 1500 Lifting Height (mm): 1600, 2500, 3000, 3500

DELTA TP AC-evo

With a built-in leg lift, the DELTA TP is the perfect solution to handle loads in places where you need to pass over ramps, skids, small obstacles and floor irregularities.



Handles two loads simultaneously, one on the forks and the second on the legs.



AC technology
+ Performance
+ Driving control
- Service Costs

FULLY POWERED STACKERS

Feature in details: _____



LEGS LIFTING:

A hydraulic lift adjusts the height of the supporting legs, increasing the clearance between the floor and machine base, enabling the stacker to safely operate on ramps and slopes while simultaneously handling two loads.

4 VIE AC-evo

4 Directions of travel

Capacity (kg): 1200 - 1500 - 2000 Lifting Height (mm): 1600, 2500, 3000, 3500

4 VIE AC-evo

Movement in 4 directions solves the problems associated with handling wide loads such as bars and pipes in confined spaces and narrow aisles.



Lateral movement left or right



Movement forward and reverse

AC technology
+ Performance
+ Driving control
- Service Costs



FULLY POWERED STACKERS

Features in detail: _____



DIRECTION VARIATION:

A hydraulic control rotates the orientation of the wheels by 90° with respect to the forks, thus varying the direction of travel forward and reverse or left and right to handle bulky loads and navigate in confined spaces.



DELTA TP AC-evo

model	125/16	155/16	125/25	155/25	125/30	155/30	125/35	155/35
Q Kg	1200	1500	1200	1500	1200	1500	1200	1500
C mm	600	600	600	600	600	600	600	600
I mm	1150	1150	1150	1150	1150	1150	1150	1150
L mm	2025	2045	2060	2080	2060	2080	2060	2080
X mm	275	275	310	310	310	310	310	310
X2 mm	175	175	175	175	175	175	175	175
Y mm	1575	1595	1575	1595	1575	1595	1575	1595
L2 mm	885	905	920	940	920	940	920	940
M mm	560	560	560	560	560	560	560	560
N mm	180	180	180	180	180	180	180	180
h1 mm	1990	1990	1740	1740	1990	1990	2250	2250
h2 mm	1450	1450	200	200	200	200	/	/
h3 mm	1600	1600	2500	2500	3000	3000	3500	3500
h4 mm	2120	2120	3020	3020	3520	3520	4020	4020
B mm	840	840	840	840	840	840	1000	1000
WA mm	1770	1790	1770	1790	1770	1790	1770	1790

STANDARD EQUIPMENT

- AC three-phase technology traction motors • Electronic plant 24V with controller with mosfet technology complete with inverter and microprocessor fault research • Regenerative braking with consumption reduction and temperature control of the traction motor • Free lift 200 mm (excluded lifting height mm 3500) • Built-in electronic battery charger 24V 30A with microprocessor • Forks control by hydraulic distributor • Support legs lift by hydraulic distributor • Fixed forks length mm 1150 • Electric end stroke • Parking Brake • Shock absorber on driving-wheel • Side wheels with extra-heavy castors • Exhausted battery warning-indicator • DR-EVO Steering • Automatic speed reduction • Safety components • Traction Battery 24V from 160 to 270 Ah

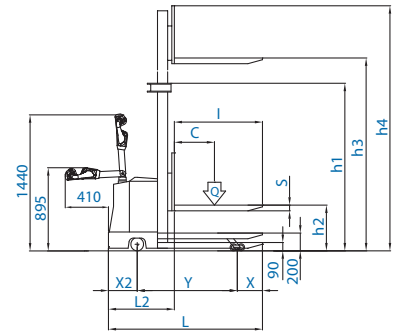
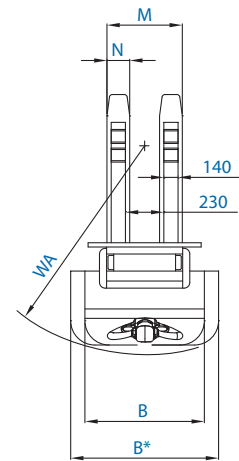

4 VIE AC-evo

model	125/16	155/16	200/16	125/25	155/25	200/125	125/30	155/30	200/30	125/35	155/35	200/35
Q Kg	1200	1500	2000	1200	1500	2000	1200	1500	2000	1200	1500	2000
C mm	450	450	600	450	450	600	450	450	600	450	450	600
I mm	950	950	1150	950	950	1150	950	950	1150	950	950	1150
L mm	1780	1780	1805	1810	1810	1835	1810	1810	1835	1810	1810	1835
X mm	310	310	310	330	330	330	330	330	330	330	330	330
X2 mm	175	175	175	175	175	175	175	175	175	175	175	175
Y mm	1285	1285	1285	1305	1305	1305	1305	1305	1305	1305	1305	1305
L2 mm	840	840	865	860	860	885	860	860	885	860	860	885
M mm	350/1300	350/1300	350/1300	350/1300	350/1300	350/1300	350/1300	350/1300	350/1300	350/1300	350/1300	350/1300
N mm	160	160	160	160	160	160	160	160	160	160	160	160
h1 mm	1990	1990	1990	1740	1740	1740	1990	1990	1990	2250	2250	2250
h2 mm	1450	1450	1450	200	200	200	200	200	200	/	/	-
h3 mm	1600	1600	1600	2500	2500	2500	3000	3000	3000	3500	3500	3500
h4 mm	2070	2070	2070	2970	2970	2970	3470	3470	3470	3970	3970	3970
B mm	1620	1620	1620	1620	1620	1620	1620	1620	1620	1620	1620	1620
WA mm	1510	1510	1510	1510	1510	1510	1510	1510	1510	1510	1510	1510

STANDARD EQUIPMENT

- AC three-phase technology traction motors • Electronic plant 24V with controller with mosfet technology complete with inverter and microprocessor fault research • Regenerative braking with consumption reduction and temperature control of the traction motor • Free lift 200 mm (excluded lifting height mm. 3500) • Extruded mast with lateral contrast bearings • Built-in electronic battery charger 24V 30A with microprocessor • Forks control by hydraulic distributor • Hydraulic directional front-wheel • Adjustable forks length mm 950 • Electric end stroke • Parking Brake • Shock absorber on driving-wheel • Side wheels with extra-heavy castors • Exhausted battery warning-indicator • DR-EVO Steering • Automatic speed reduction • Safety components • Traction Battery 24V from 160 to 270 Ah

